

RAIN GARDEN

Protecting Schoolyard Streams from Stormwater Runoff

Andrea Ludwig, Associate Professor, Department of Biosystems Engineering and Soil Science

Jennifer DeBruyn, Associate Professor, Department of Biosystems Engineering and Soil Science

Jennifer K. Richards, Extension Curriculum Specialist, 4-H Youth Development



Rain Gardening

Protecting Schoolyard Streams from Stormwater Runoff

Skill Level

Advanced (9th-12th graders)

Learner Outcomes

The learner will be able to:

- Define new vocabulary words
- Calculate rain garden size relative to soil infiltration
- Create a planting design based on size and soil moisture conditions

Educational Standard(s) Supported

CLE 3260.42

CLE3255.6.4

CLE3260.6.1

Success Indicator

Learners will be successful if they:

- Understand the purpose of rain gardens and can explain their planting design

Time Needed

Up to 60 minutes

Materials List

Rain garden worksheet

Clipboard

Calculator

Standard graph paper

Colored markers

Authors

Andrea Ludwig, Associate Professor

Jennifer DeBruyn, Associate Professor

Department of Biosystems Engineering and Soil Science

Jennifer K. Richards, Extension Curriculum Specialist,

4-H Youth Development

Introduction to Content

A rain garden is a planted depression that is built to capture and infiltrate stormwater runoff from impervious surfaces, like rooftops and parking areas. Students will learn about this topic.

Terms and Concepts

Hydrologic cycle: The continuous movement of water on, above and below the earth's surface.

Hydrologic soil: A grouping system for soils-based texture, structure and transmission.

Soil infiltration: The process by which water on the surface enters the soil.

Stormwater runoff: Runoff that originates as rainfall or snow melt that does not soak into the ground. Usually associated with impervious surfaces.

Watershed: The land area that drains to a common point.

Impervious surface: A surface that does not allow water to infiltrate.

Rain garden: A planted depression that is built to capture and infiltrate runoff from impervious surfaces.

Introduction to Methodology

Students will design a rain garden based on soil characteristics, drainage area and planting plan. Students may use the scenario provided, or they may be given the opportunity to investigate the soils in their school yard and design a unique rain garden specifically for their school. If the latter, then use one of the activity options to gather the soils information needed to perform the design.



Setting the Stage

Ask students: “What was here on the land before it was a school? Was it a forest, a meadow, a grassy pasture? When it rained on the forest or meadow, what happened to the rain? And now, what covers the land? Pavement, rooftops, turf grass? When it rains now, what happens to the rain that falls on the rooftop and pavement?”

“Land development leads to an increase in impervious surfaces in watersheds, which means more runoff to streams. Streams in developing watersheds show symptoms of the “urban stream syndrome,” like bank erosion, turbid or cloudy water when it rains, and down cutting. Rain gardens are one way to mitigate for impervious surfaces by catching the runoff before it gets to the stream and infiltrating it into the ground, as it did before the buildings and roads were built. The place to build a rain garden is between the source of runoff (the impervious surfaces) and the infrastructure that carries it off the property (via storm drain, ditch, etc.) or stream. Rain gardens should not be built above underground utilities, under drip lines of existing trees, within 10 feet of buildings, within 25 feet of septic systems or on highly sloped areas.”

Experience

Options to gather the soils information needed to build the design:

1. Visit the web soil survey to look up the hydrologic soil group and texture of the soils in the schoolyard.
2. Perform a ball and/or ribbon test. Take a soil sample from the schoolyard (remove the organic top layer). In the palm of your hand, moisten the soil and work it around with your fingers and form a ball of soil. Take the ball between your thumb and index finger and apply pressure. Observe the ball and consult the table below. Now, take the soil and work into a thin ribbon between your thumb and index finger. Push out the ribbon until it breaks off and consult the table below.
3. Perform a percolation, or perc, test. Dig a 1-foot-deep and 1-foot-wide hole, scraping up the sides so they are not slicked. Fill with water and allow to drain. Immediately fill the hole again and monitor the rate in which water infiltrates into the ground (i.e. 6 inches over 12 hours, or 1/2 inch per hour). Consult the table below:

Strategies to Increase Student Engagement

- **GO OUTSIDE!**
- Take the students on a schoolyard tour and look for impervious surfaces or signs of urban stream syndrome.

Teacher Notes

Soil	Ribbon Test	Ball Test	Expected Percolation Test	Sizing Rule
Sand	Does not form ribbon	Falls apart with pressure	More than 1.5 inches per hour	0.1
Silt	Forms a weak ribbon less than 1.5 inches and breaks	Cracks with pressure	0.75-1.5 inches per hour	0.15
Clay	Forms a ribbon more than 1.5 inches	Is pliable and does not form cracks	0.25-0.75 inches per hour	0.2

For designing your own schoolyard rain garden, measure the dimensions of the contributing drainage area – this is the rooftop and/or paved area that drains to the rain garden. For example, if the intention is to disconnect two downspouts draining a corner of the school building, then measure the roof area that drains to those downspouts. Consider using Google Earth with your students to measure this digitally.

For the given scenario, students will use a sheet of standard graph paper as their design canvas. For scale, use one graph box equals .5 feet or 1 foot is the length of two boxes. (The maximum size rain garden that can be designed on a standard sheet of paper is 336 ft².) The drainage area table for the given scenario is below:

Impervious Surface	Length (ft)	Width (ft)	Area (ft ²)
Rooftop	25	20	500
Bike Path	70	10	700
Total:			1200

Rain garden sizing rule selected should be 0.2 and the garden area needs to be 240 ft². The table below lists general dimensions associated with garden area. Rain gardens are generally jelly-bean shaped, but for simplicity, a square with rounded corners will do.

Area (ft ²)	Width (ft)	Length (ft)	Area (ft ²)	Width (ft)	Length (ft)
100	8	13	240	14	17
140	10	14	280	16	18
180	12	15	300	16	19
200	13	16	330	17	20

The arrangement of plants in the rain garden based on their size and soil moisture growth conditions is called the planting plan. A set of stencils is provided to help with creating the design. Students will cut out the selected plants and arrange the plants on the grid canvas until they are happy with the design. Then glue the plan circles on the graph paper in the final arrangement. With the stencils provided, there are several options for this part of the activity:

1. Each unique stencil may be designated a specific plant name from the list (there are enough designs in the correct dimensions to accomplish this). Students may use the key to identify the plants selected for their design.
2. Students may use the width dimension labeled on the stencil and assign it a plant type themselves by coloring the stencil the color indicated on the plant list.
3. Stencils may be pre-cut, laminated, and placed in baggies for a reusable set-up.

Share

Ask students to pair with a partner and share their rain garden design. Encourage students to explain and justify why they chose each type of plant and the arrangement of their garden.

Process

Within student pairs, ask each partner to share:

- Three things about their partner's design they thought were strong.
- Two suggestions for improving their partner's design and why the suggestion will improve it.
- One improvement they would make to their own garden based on something they saw in their partner's garden.

Generalize

Have each pair research online to find an example of a rain garden. Ask them to compare and contrast their designs to the example they found online.

What recommendations would they make to the garden designer to improve the rain garden?

What changes would students make to their own gardens based on the example they found online.

Apply

The advantage of having students cut out and glue plants is that students will be able to take home their garden design to share with their parents, opening the door to the possibility of their family creating a rain garden at their home.

Ask students to take their design home and complete a "walkabout" around where they live. Are there locations where they could implement their rain garden design? If not, how could they modify their design to be practical where they live?

For example, if students live in an apartment, what modifications could they make to ensure their design is practical? Could it be modified to fit in a window box? Or on a deck or balcony? Could they talk to apartment managers to take over a flower bed or some other small space on the grounds to implement a rain garden?

TIPPS *Life Skills*

Using critical thinking skills to accomplish a task. (Head, Thinking)

Applying learned concepts to make a model. (Hands, Working)

Supplemental Information
Educational Standards Addressed

CLE 3260.42
CLE3255.6.4
CLE3260.6.1

Plant List for Tennessee

Rain Garden Plant	Growth Size (ft)		Soil Moisture	Bloom Color
	Height	Width	Condition	
Star Sedge	2	1	W	Green
Brown-eyed Susan	3	1	D	Yellow
Blue Lobelia	3	1	W	Blue
Cardinal Flower	3	1	W	Red
Blue Flag Iris	2	2	W	Blue
Swamp Milkweed	4	2	W	Pink
Mistflower	2	2	M	Purple
Beebalm	2	2	M	Red
Turtleheads	3	2	W	Green
River Oats	3	2	D	Green
St. <u>Johns</u> Wort	3	2	D	Yellow
Ironweed	6	3	M	Purple
Bluestar	3	3	D	Blue
Joe Pye Weed	5	3	D	Pink
Golden Rod	2	3	W	Yellow
Bluestem	5	3	M	Green
Switchgrass	5	3	M	Green
New England Aster	4	3	W	Purple
Soft Rush	3	3	W	Green
Virginia <u>Sweetspire</u>	4	4	M	Green
False Indigo	4	4	M	Blue
<u>Summersweet</u>	5	5	M	Green / White
Beautyberry	6	5	M	Green / Purple
Chokeberry	5	5	W	Green / Red
Winterberry	8	6	M	Green / Orange
Buttonbush	10	6	W	Green / White

References:

Photos of rain gardens in Tennessee: www.tinyurl.com/tnsyraingardens

Web Soil Survey: <http://websoilsurvey.sc.egov.usda.gov/App/WebSoilSurvey>

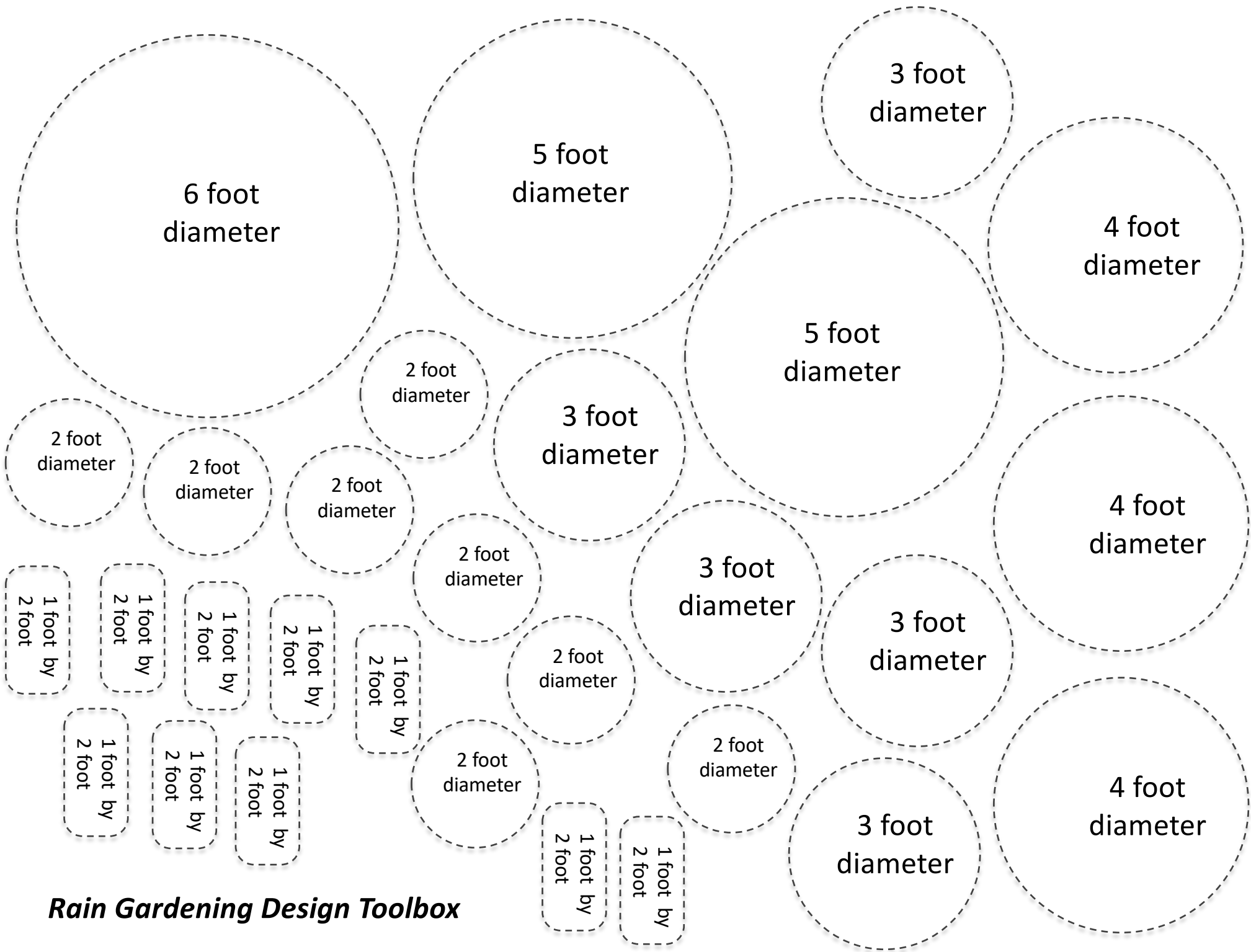

Rain Gardening Design Toolbox











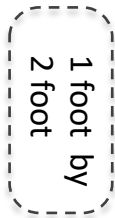
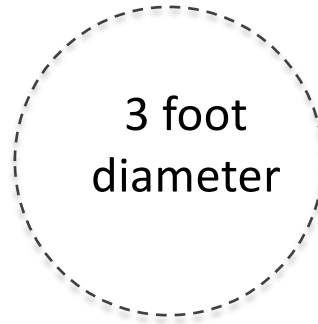
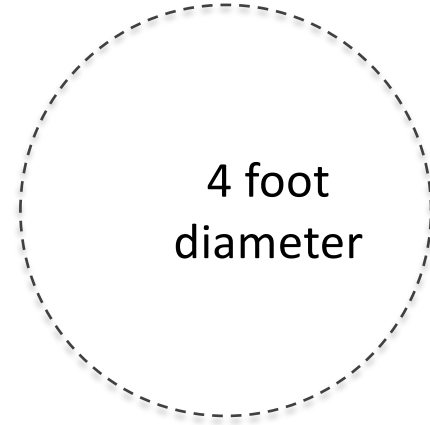
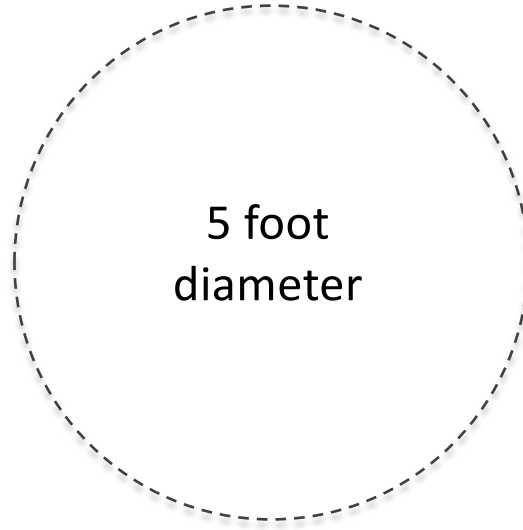
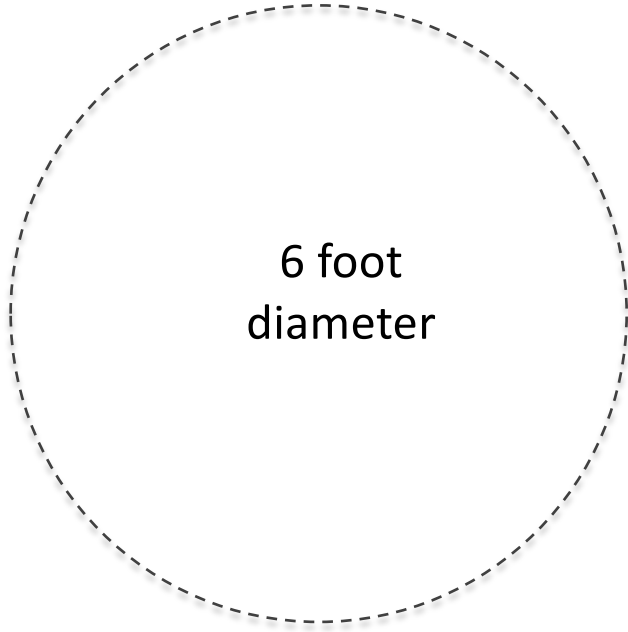

Rain Gardening Design Toolbox

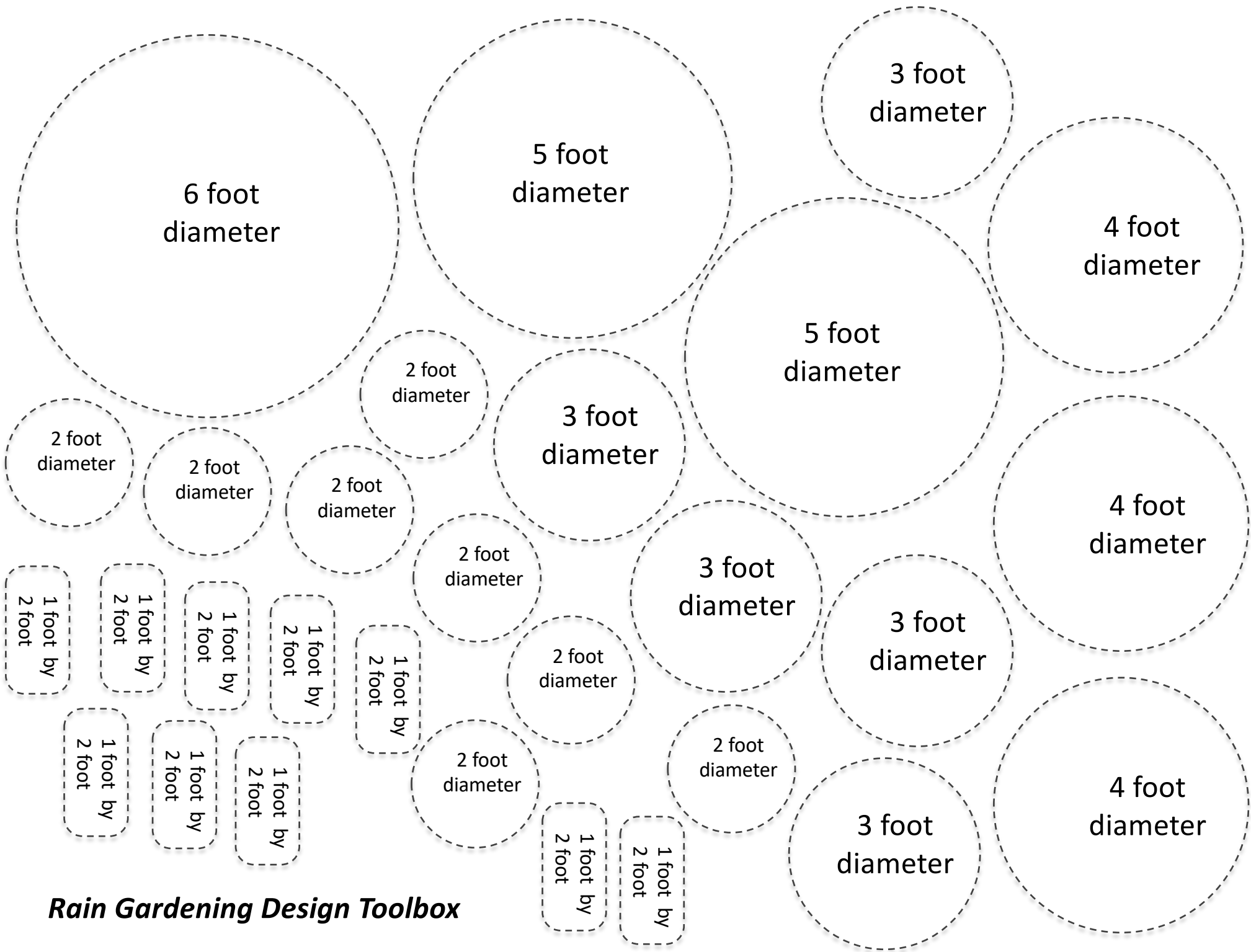

Rain Gardening Design Toolbox

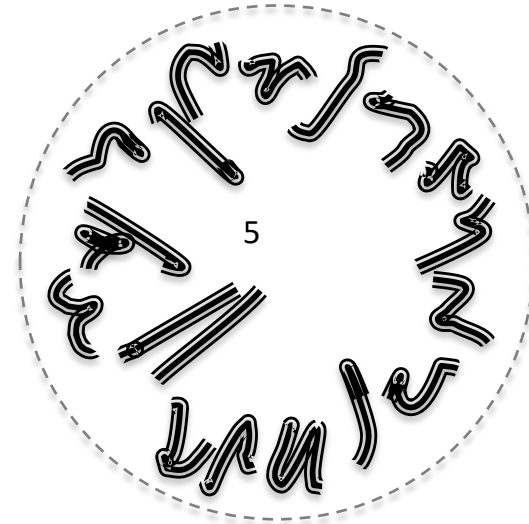
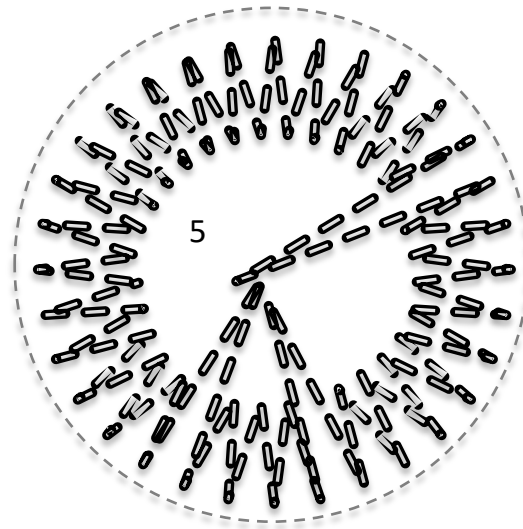
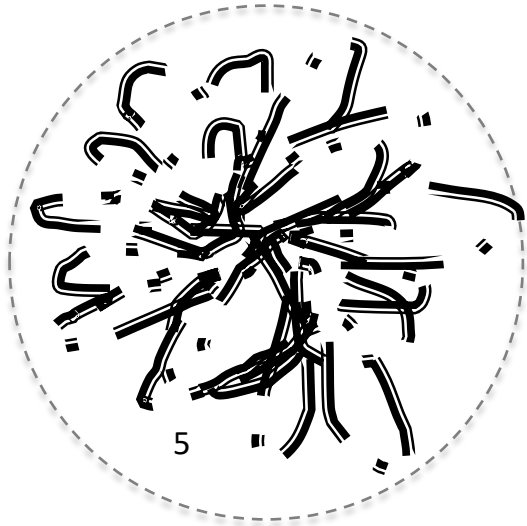
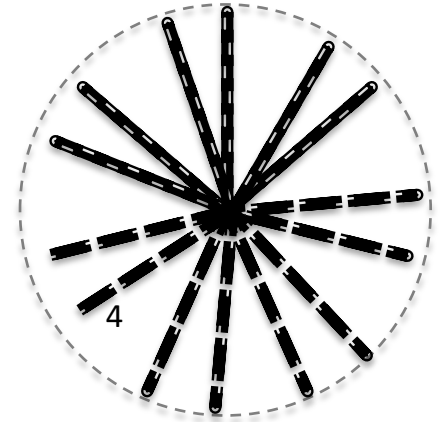
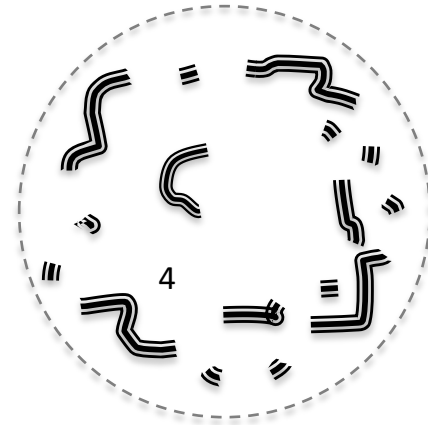
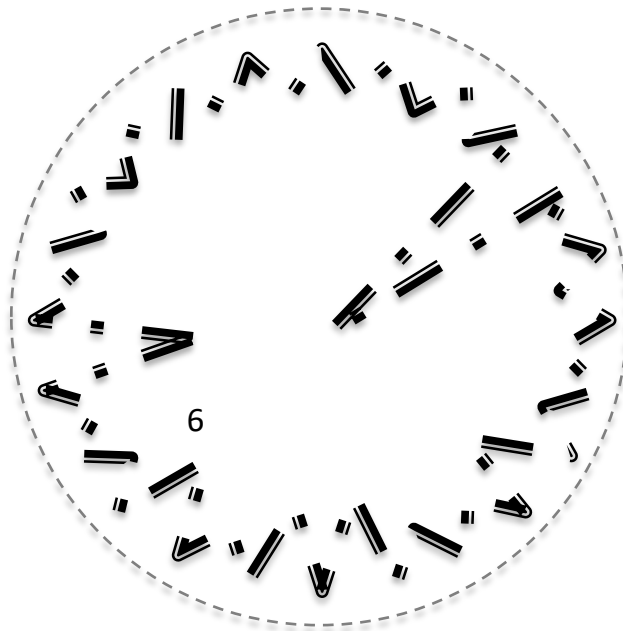
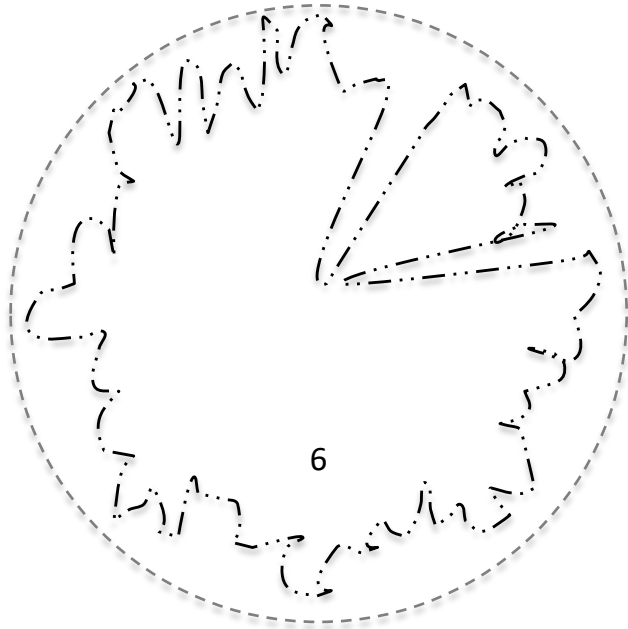

Rain Gardening Design Toolbox

Rain Gardening Design Toolbox

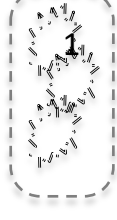
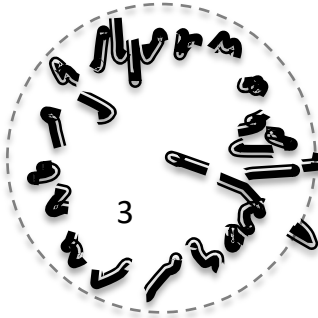
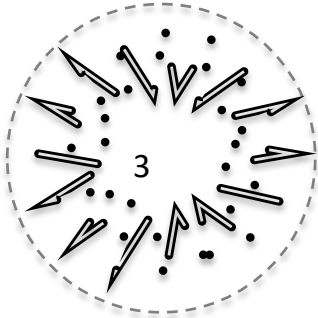
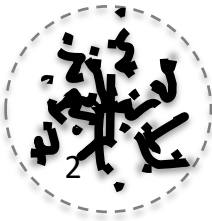
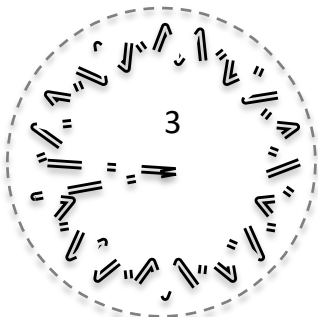
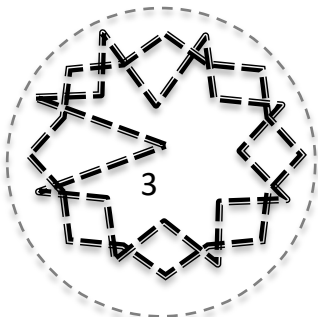
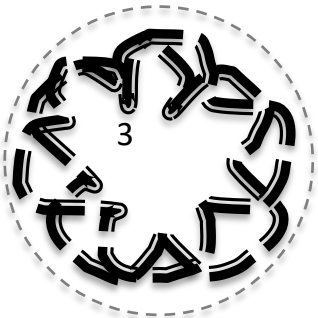
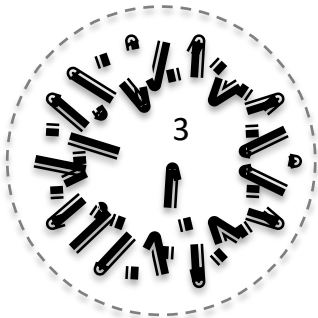
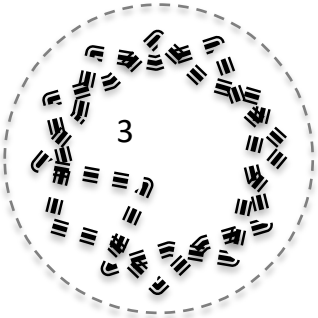
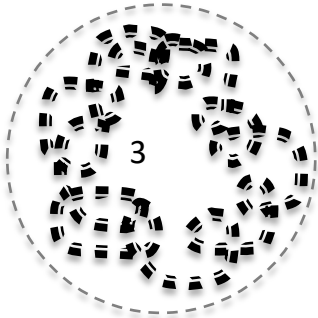

Rain Gardening Design Toolbox

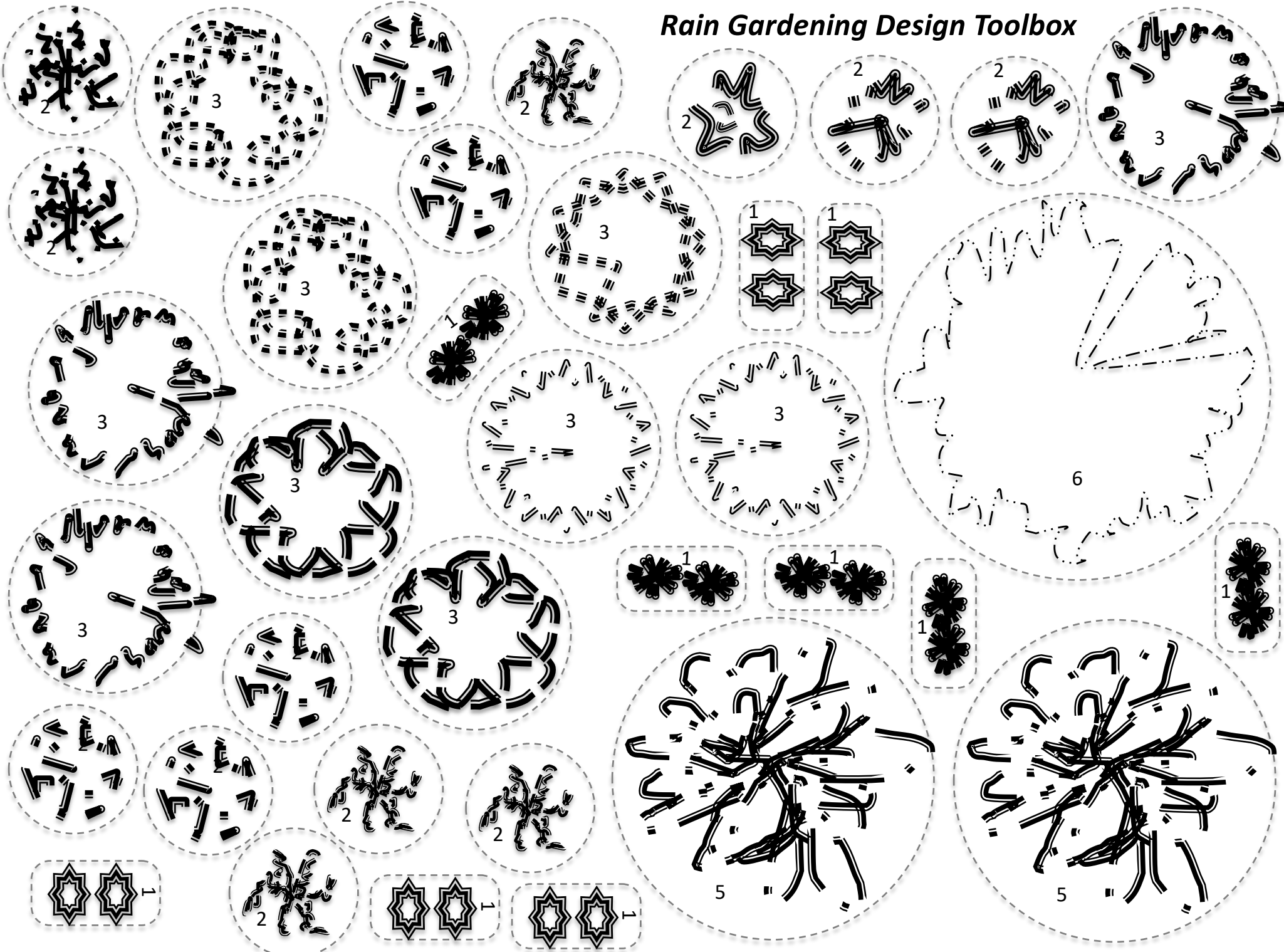



UTIA.TENNESSEE.EDU

Real. Life. Solutions.™